

LED EMERGENCY

Twin Spot Self-test Light

EMRTS-LED

This non-maintained twin spot luminaire will provide 3hrs of emergency lighting in the event of a power cut and has a lumen output of 205 per lamp, while consuming a total of just 6 Watts.

It's constructed from polycarbonate, weighs just 2.8kg and has an IP65 rating to make it waterproof. It also has useful 'Lamps OK', 'Status' and 'Charge' indicators. Takes 3.6V 600mAh Ni-Cd batteries.

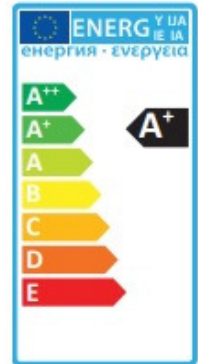

Technical information

Model	Wattage	Lumens	Battery Type	Construction	Applications	Weight
EMRTS-LED	2 x 3W	205 (each)	3.6V 6Ah NiCd batteries	Polycarbonate Body	Industrial/ Warehouse & Corridors	2.8kg

Dimensions

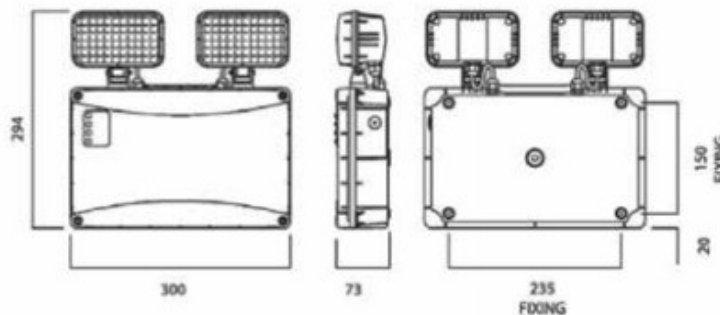

Compliance

✓ BS EN 60598-1:2015 Luminaires. General requirements and tests

Class 1: Electricity insulated and provided with connection for earth.  Designed for LUMiLiFe Great Britain

Indoor    ErP

LUMiLiFe is constantly developing and improving its products. For this reason, all product descriptions are intended as a general guide and we may change specifications time to time in the interest of product development, without prior notification or public announcement. Data in this sheet has been obtained in controlled experimental conditions. However, LUMiLiFe cannot accept any liability arising from the reliance on such data to the extent permitted by law.