

Technical Information

3rd Angle

Design

Standard: BSEN40

Finish

Mill finish

Welding

In accordance with BSEN1011
 Procedures to BSEN ISO 15614-1:2017
 Welders qualified to BSEN ISO 9606-1:2017

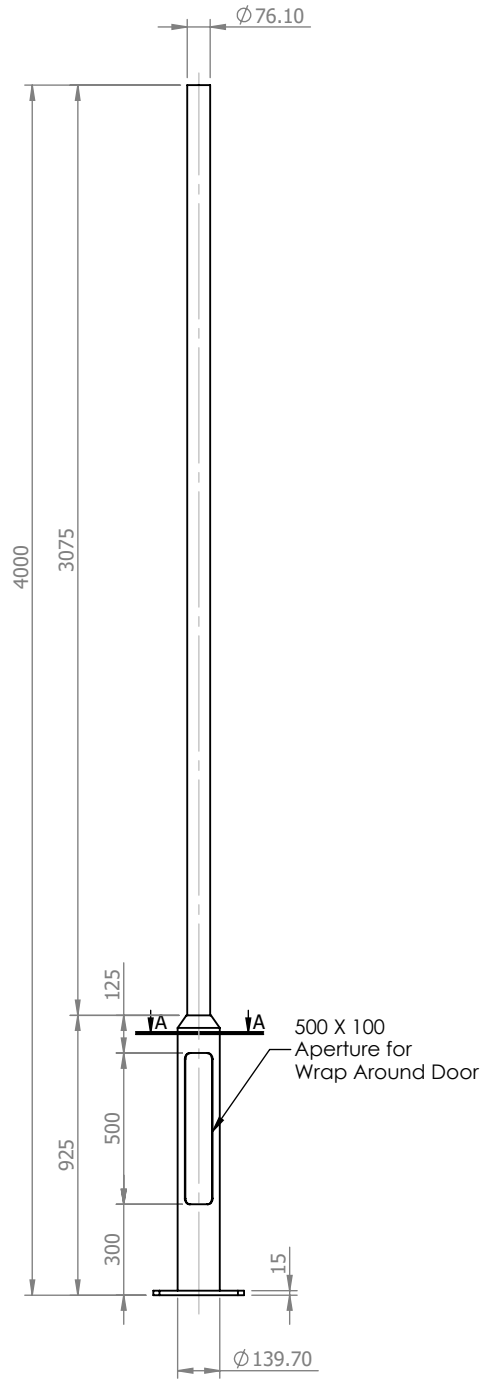
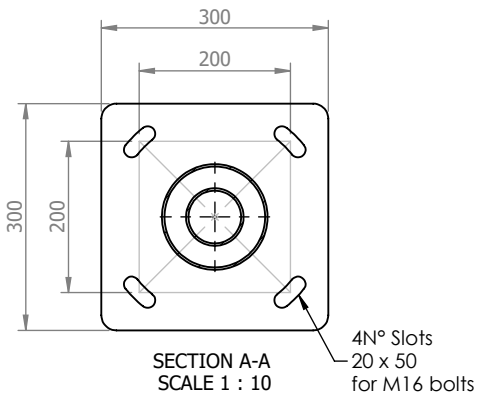

2020 © Copyright

fabrikat

Nottingham Limited, Hamilton Road,
 Sutton in Ashfield Notts. NG17 5LN

www.fabrikat.co.uk

Tel.01623 442200

technical@fabrikat.co.uk

Fax.01623 442233

Notes

All dimensions in millimetres unless stated otherwise.

When Multiple views are shown 3rd Angle Projection is assumed.

Revisions		
Rev.	Description	Date

Title

4 Metre Flange Plated Tubular Post Top Column

Drg No. 29350-0

Scale:1:25

Sheet 1 of 1

Drawn By: mls

Chk'd: mb

Ref. 4M01A FP

Contract:

Customer:

Date: 04/02/2013